

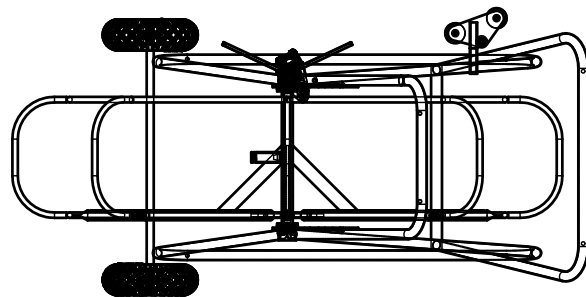

Ausführungen RSH 350 und RSH 600 ohne Räder

Code	Type	A	B	C	D	E	F	G	H	J	K	kg
226.010	RSH 350	370	265	430	170	320	15	45	-	150	-	2,35
226.020	RSH 600	620	485	690	240	550	15	55	-	155	-	5,0
226.070	RSH 800	820	635	915	255	755	30	65	180	210	405	13,3
226.090	RSH 1000	1030	760	1150	380	985	45	75	180	260	525	21,1
226.120	RSH 1200	1210	880	1345	395	1185	55	80	180	295	540	26,6

 VETTER GMBH Kabelverlegetechnik D-79807 Lottstetten	Oberfläche		Maßstab 1:10		Position - Menge -		
		Datum	Name		RS - Haspel RS - Reel RS - Dévidor RS - Devanadera		
		Bearb.	15.07.2009	jl			
		Gepr.	24.07.09	W. Saum			
		Norm					
					226.001.02-4		Blatt
							-
							Bl
Zust.	Änderungen	Datum	Name	Dateiname D:\VETTER\Haspeln\Massblatt.dwg			

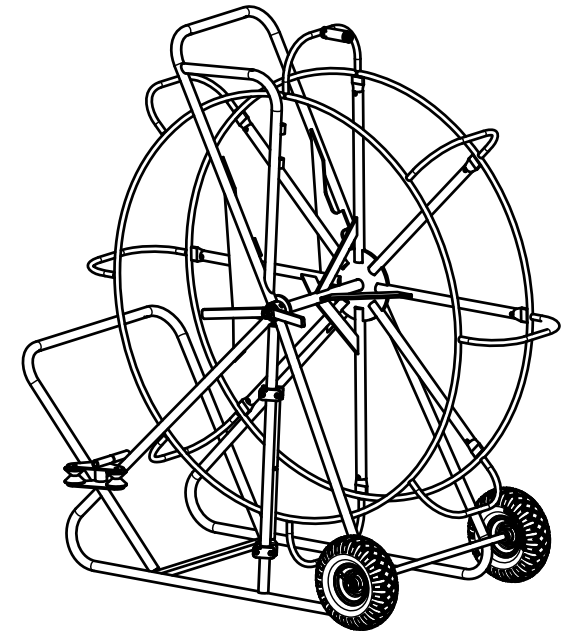
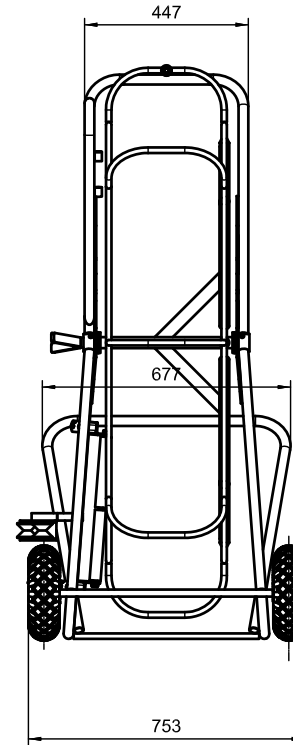
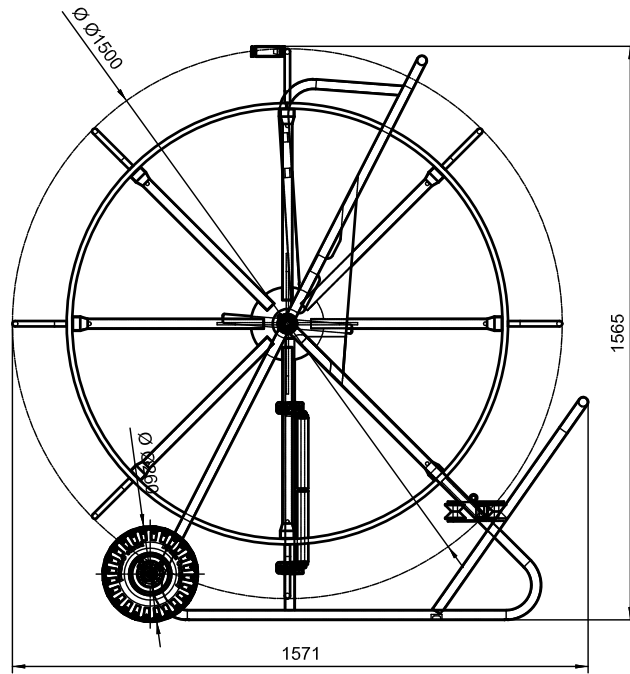

 VETTER GMBH Kabelverlegetechnik D-79807 Lottstetten	Freimaß-Toleranz nach ISO 2768-1 mittel / -2 K	Oberflächen DIN ISO 1302	Maßstab 1:10 Werkstoff	Position Menge	
	Datum Name	Name SS VE	Haspel RSH		
gez. 24.03.16 gepr. 24.03.16 Norm	Datum Name	RSH 1500			226.131.25-2
Zustand	Änderung	Datum	Name	Gewicht: 50 kg	Größe A2